

Solar Intelligent Toilet



Renewable Energy
Self sustainable

Water Saving
Mobile



An Innovative Mobile Lavatory System

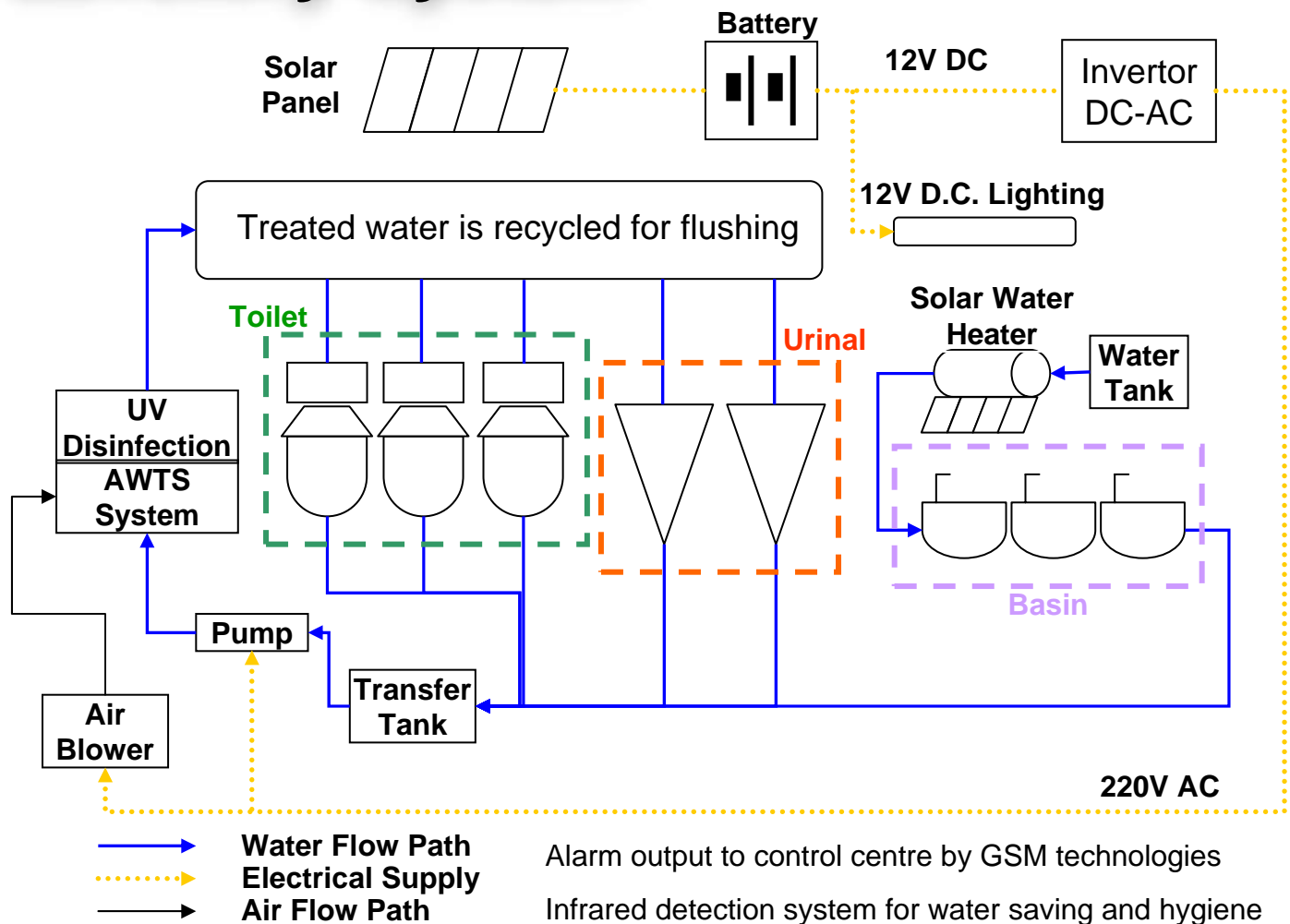

SPECIFICATION

General Description

Number of Toilet	3 nos.
Number of Urinal	2 nos.
Number of Basin	3 nos.
Flushing Capacity	250 times/day (Max. 300)
Volume of AWTS system	AWTS-J8 (3150 L)
Air Pump Capacity	40 m ³ /min

Toilet Structure

Toilet Structure	220V, 350W
Toilet Partitions	220V, 50W
Toilet Floor	220V, 20W

Electrical Installation

Effluent Transfer Pump	220V, 350W
Air Pump	220V, 50W
Lighting	220V, 20W
Ventilation Fan	220V, 15W

Solar and Power Installation

Power Supply	220V, 800 kVA
Solar Power	75W/panel
Battery Module	150Ah/ module
Solar Controller	Morning Star
Power Inverter	12V DC ~ 220V AC



Waste & Environmental
Technologies Ltd.
保然技術有限公司

Units 601& 602, 6/F, Lakeside 2, No. 10 Science Park West Avenue,
Phase II, Hong Kong Science Park, Shatin, New Territories, Hong Kong
Tel: (852) 2602 0308 Fax: (852) 2694 7757
Webpage: www.wastech.com.hk E-mail: mail@wastech.com.hk